

TOX

Track Installation & Wiring Guide

LIVE END FEED STEP-BY-STEP INSTRUCTIONS



Please refer to the QR CODE for detailed, step-by-step instructions for wiring the end feed.
Contact Cielux Customer Support (cielux@cielux.com) for any questions

READ AND SAVE ALL INSTRUCTIONS

When installing or using this track system, basic safety precautions should always be followed, including the following:

1. Read all instructions.
2. Do not install this track in damp or wet locations.
3. Do not cut any track section (unless provision is made for field cutting).
4. Do not install any part of a track system less than 5' above the floor.
5. Do not install any fixture assembly closer than 6" from any curtain or similar combustible material.
6. Disconnect electrical power before adding to or changing the configuration of the track.
7. Do not attempt to energize anything other than lighting track fixtures on the track. To reduce the risk of fire and electrical shock, do not attempt to connect powertools, extension cords, appliances, and the like to the track.
8. Do not connect the track to more than one branch circuit unless the track is constructed so that it can be used with more than one branch circuit. (For track lighting systems other than 120 V, two-wire)
9. Check with a qualified electrician. Although the track lighting system may seem to operate acceptably, a dangerous overload of the neutral may occur and result in a risk of fire.
10. The track system is not intended for use with a power supply cord or convenience receptacle adapter.
11. For the recessed version, please use the following drywall thicknesses: 1/4" ; 5/16" ; 3/8" ; 1/2" ; 5/8".

2 CIRCUITS WITH COMMON NEUTRAL + DATABUS

Dimensions-

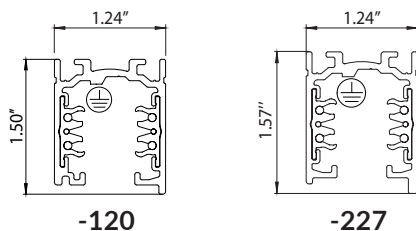

Polarity-

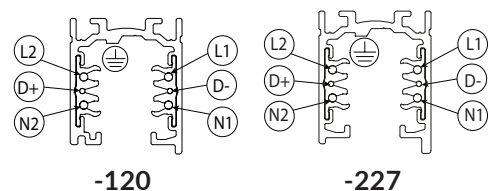

This track is a four-power-conductor system. These conductors can be used in 2 circuits with common neutral configurations. There are 2 additional conductors used for the databus (for example DMX, 0-10V, LON, EIB, DALI). The databus is a Class 2 circuit. If the databus is used as a non-Class 2 circuit then the conductors must be recessed using the bending tool as the conductors are not provided recessed from the factory.

The system is UL 1574 certified and its installation must be done by qualified personnel only.

There are four possible installation systems:

The track may be installed directly on the ceiling or wall using the mounting holes (use a countersunk head screw, Pic. 1), using a metal clip, or recessed without exceeding the maximum loads (Pic. 2). During wiring, the electrical scheme shown in Pic. 3 must be followed.

Pic 1.
Mounting holes position and fixing with screw

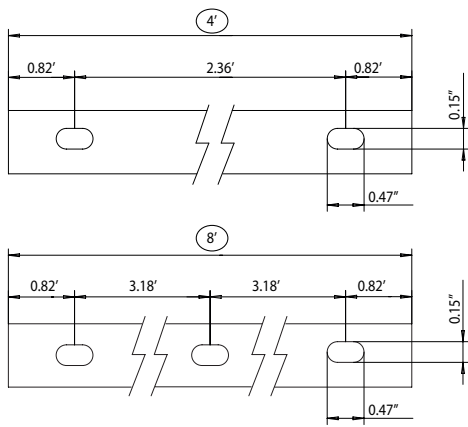

Pic 2.
Load Scheme

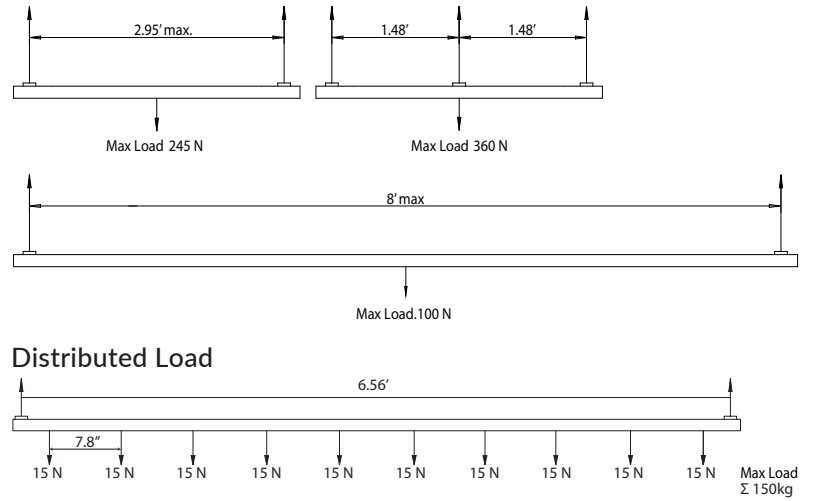

Pic 3.
Electrical Scheme

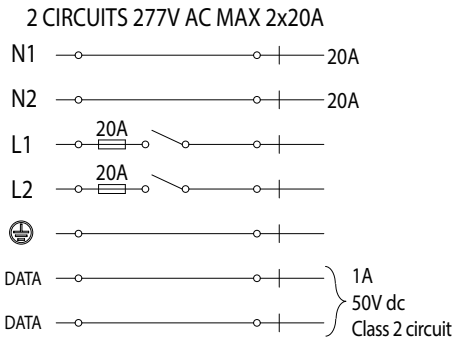
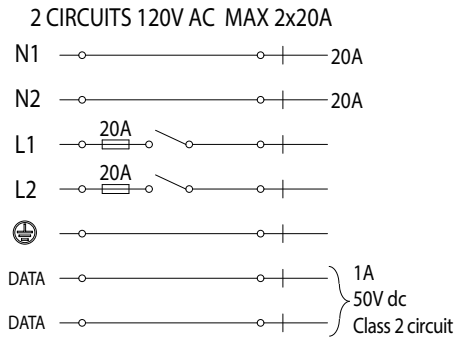

END FEED COMPONENT WITH PIN-OUTS

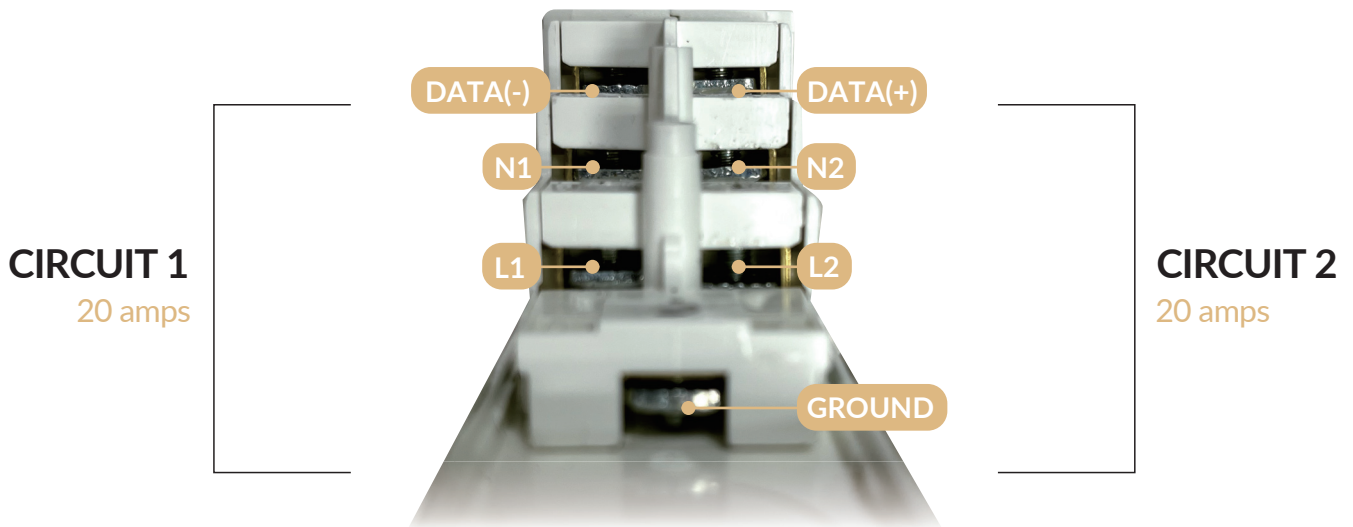

The track bars with length 4' or 8' are provided with the copper conductors already recessed, in compliance with the relevant safety standard. If it is necessary to shorten the track during installation this operation must be done with a tool intended for cutting aluminum. After the cutting operation, it is necessary to bend the power conductors using a tool to recess the four power conductors by at least 0.19" so that the correct air, surface and electrical distances are respected (Pic. 4 and 5).

Pic 4.
Recessing track conductors

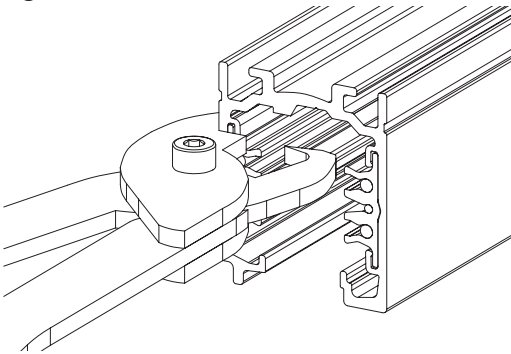

Pic 5.
Minimum recessing distance

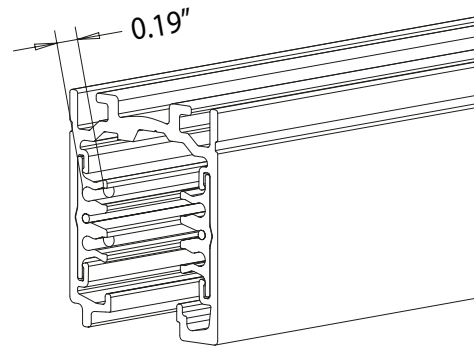

MOUNTING INSTRUCTIONS FOR RECESSED USE OF THE TRACK

Remove End Feed Cover

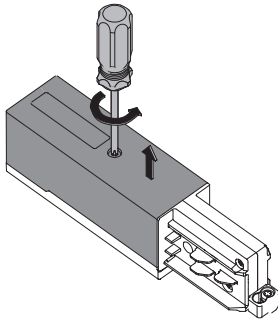

Knock out predrilled hole for cabling

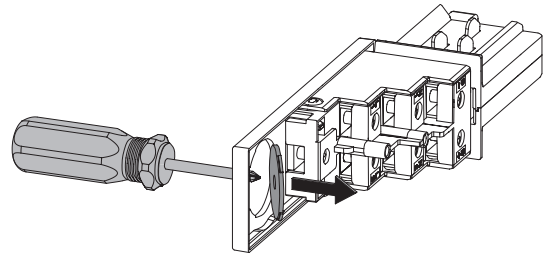

For the wiring of the end-feed use the following wire according to NEC/CEC: 5 x 12AWG or 7 x 12AWG. Unscrew and remove the end-feed so that contacts are visible. (Pic. 6) Knock-out the detachable wall 1 or 2 (Pic. 7) and create a hole, then make the wire pass through it. Remove the protective covering from the wires for about 3.15" then strip the wires for 0.39-0.43" (Pic. 8).

Pic.6
End-feed screws

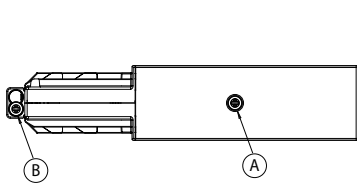

Pic.7
Knock-out walls

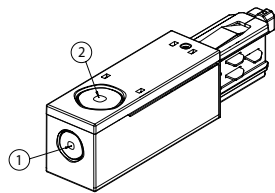

Pic.8
Length of the wires

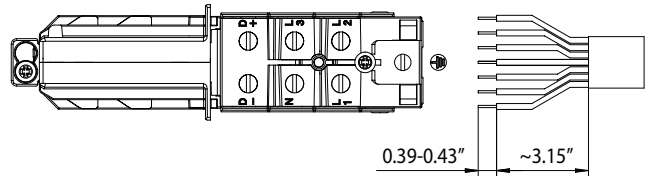

Insert End Feed to Track

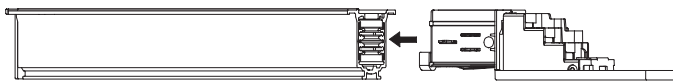

Secure End Feed

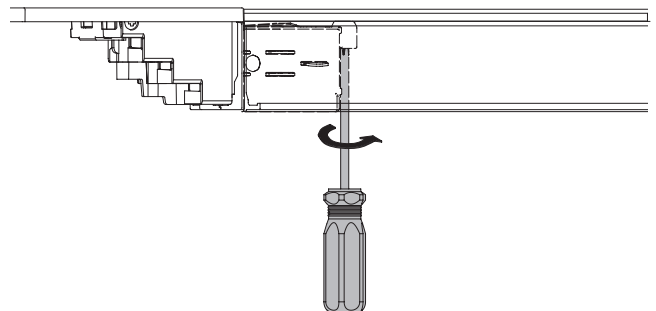

After that proceed with wiring to the end-feed contacts respecting the marking on it (L1/L2/L3/N/T/D+/D- or L1/L2/N1/N2/T/D+/D-). The DMX signal requires two signal carriers and the polarity of the DMX conductors is labelled next to the corresponding screws (Pic. 8).

Insert End Cap to Track

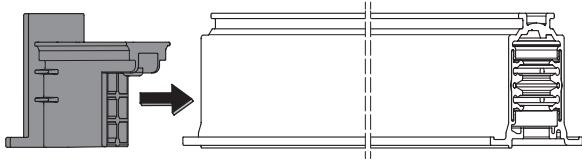

Secure End Cap

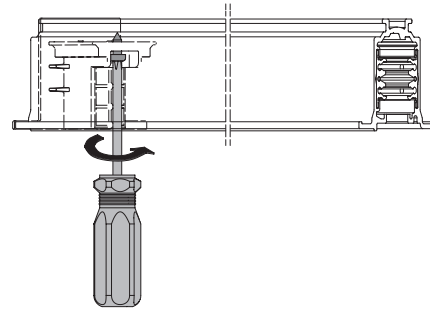

Insert Expansion Screw to Ceiling, Insert Screw

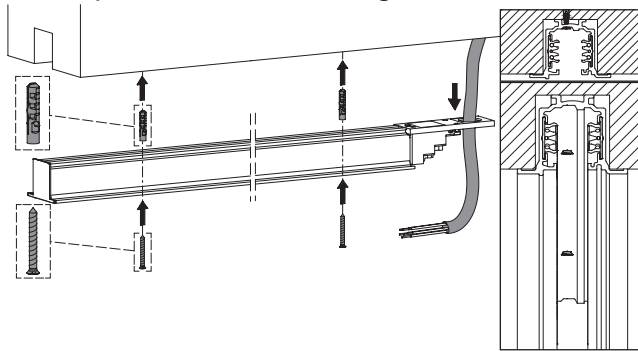

Secure Cables

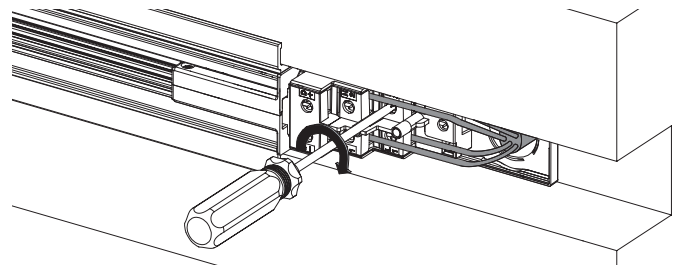

Secure End Feed Cover

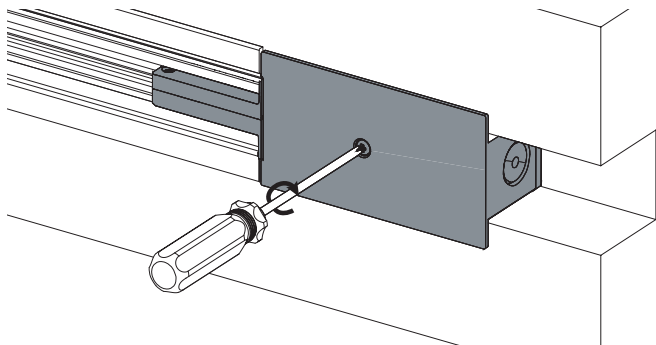

END-FEED: 9001/... AND 9002/...

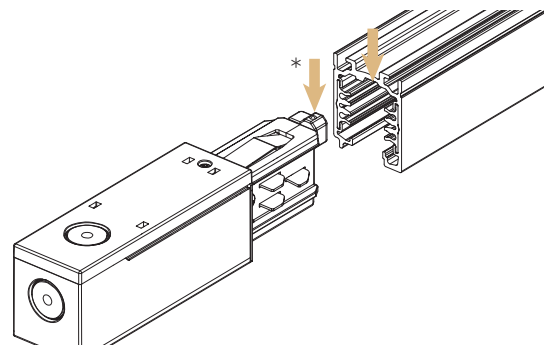

After wiring, place the cover on the end-feed and tighten A screw. Finally insert the end-feed into the track and secure it.

*In order to guarantee the correct wiring of the system the end-feed is provided with a mechanical key that ensures the correct insertion into the track. When installing the mechanical key must be used correctly.



PLEASE ENSURE THAT THE DATA BUS WIRING DOES NOT CREATE A RING STRUCTURE. A FAILURE-FREE DATABUS CANNOT BE ENSURED IF ONE IS PRESENT.

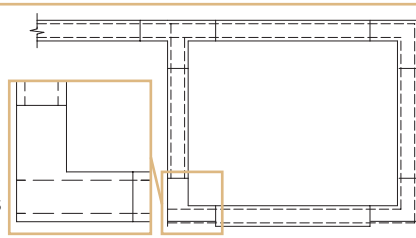

IF THE TRACK INSTALLATION REQUIRES THE USE OF "L", "T" OR "X" -SHAPED JOINT, IT IS POSSIBLE TO DISCONNECT THE DATA BUS IN THESE JOINTS TO AVOID CREATING A RING STRUCTURE.



DIRECTIVE 2012/19/EU (Waste Electrical and Electronic Equipment - WEEE) The product at the end of its life must be disposed of and recycled at a designated collection point and cannot be treated as household waste. Details on collection points are available from your local government office or the product retailer.

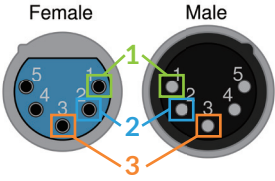
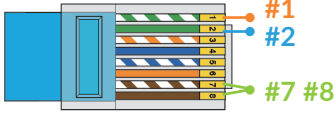
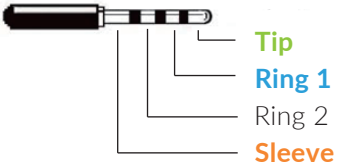

STANDARD DMX CABLING AND POLARITY

		XLR5	RJ45	TRRS
Connector				
Description		DMX lighting standard	Architectural, corporate, and fixed installations	Cielux RPU, P3 / Q3 / G3.
Connector Pin-out				
Signal	Ground	1	7, 8	Tip
	Data -	2	2	Ring1 (closest to tip)
	Data +	3	1	Sleeve